



주식회사 신원테크
SHIN WON TECH

(주)신원테크는 금속가공, 금형제작, 설계 전문 기업으로서 양질의 제품 생산을 통해 시장 요구에 만족할 수 있도록 최선을 다해왔습니다.

우수한 품질의 제품, 경쟁력 있는 가격과 신속한 납품을 약속하는 귀사의 성공파트너가 되겠습니다.



체계적이고
SYSTEMATIC



전문적이며
PROFESSIONAL



RELIABLE
믿을 수 있는 기업



목차 CONTENTS

01. 회사 정보 COMPANY INFORMATION

02. 생산관리 시스템 MANUFACTURING EXECUTION SYSTEM

03. 차별화 OUR DIFFERENTIATION STRATEGIES

05. 공정 플로우 PROCESS FLOW

04. 제품과 설비 PRODUCTS & EQUIPMENT

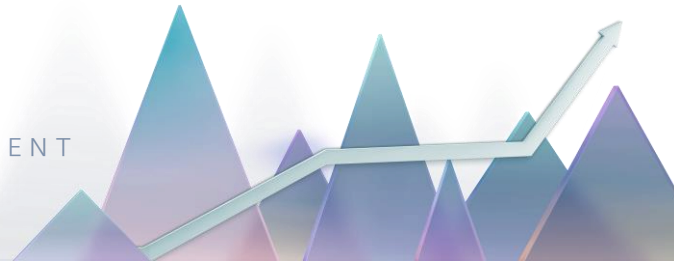



주식회사 신원테크는
지난 30년간 자체 개발부터 양산까지 가능한 기업으로서 업계에서 입지를 굳혔습니다.

1983

ESTABLISHMENT

09 신광정밀 설립

2016

INCORPORATION

05 (주)신원테크 법인설립

07~12 업체등록
현대, 기아, GM
쌍용, 르노자동차

2017

GROWTH

06 연구개발전담부서 인정
(한국산업기술진흥협회)
CLEAN 사업장 인정
(한국산업안전보건공단)

09 벤처기업 등록
(기술보증기금)

2020

INNOVATION

06 ISO14001:2015
인증

07 현대기아자동차 SQ
인증
IATF16949:2016
인증

12 SES-Tier2 인증



COMPANY INFORMATION
사업 분야

주식회사 신원테크는 자동차는 물론 주방 및 가구, 건설 등 금속을 이용한 프레스를 필요로 하는 모든 기업을 위한 서비스를 제공합니다.



2D·3D 설계

고객 니즈를 반영한
맞춤 설계

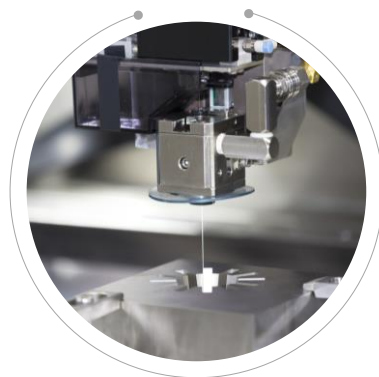

금형 제작

오차범위를 최소화한
금형 제작

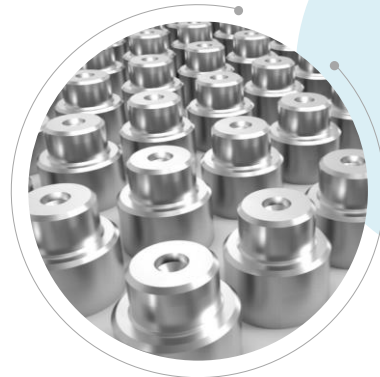

제품 제작

불량 없는
제품 생산

자동차
58%

승용 및 상용 자동차
INSIDE / OUTSIDE MIRROR의
내·외장 제품

군수
24%

군수용 자동차의
OUTSIDE MIRROR 내장제품 및
특수자동차의 외장용 제품

**모터
CORE**
11%

지하철에 사용되는
모터 CORE

기타
7%

자동차 엔진 배기구,
전자제품 내 일반 제품 등



COMPANY INFORMATION

인증

주식회사 신원테크는
경영과 생산에 필요한 모든 자격을 갖춘 사업체입니다.



CLEAN 사업장 인증



벤처기업 인증



환경경영시스템 인증

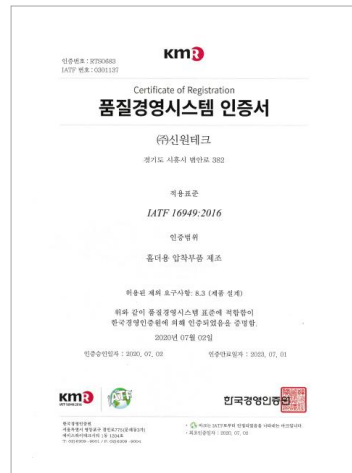

품질경영시스템 인증

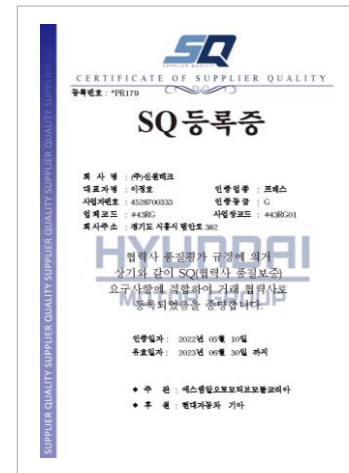

현대기아자동차 품질보증 인증

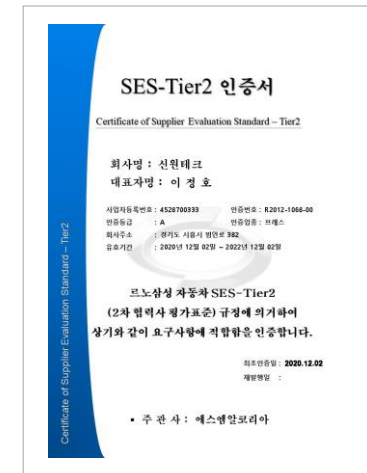

르노삼성 SES-Tier2 인증

COMPANY INFORMATION

조직

주식회사 신원테크는
각 영역에서 오랜 경험과 노하우로 보유한 사람들이 모인 전문가 집단입니다.



COMPANY
INFORMATION



고객사

주식회사 신원테크는
고객 만족을 위한 준비와 노력을 가장 중요한 가치로 생각합니다.

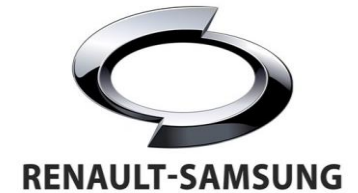

원자재부터 완제품까지 전 생산 과정에 걸쳐
실시간으로 추적하고 지원하는 효율적인 관리 시스템을 적용하고 있습니다.

Manufacturing Execution System



MRP
생산관리시스템

영업관리
생산관리
각종공정관리
재공·재고관리



LTS
로트추적시스템

추적성관리
로트관리
선입선출관리



QMS
품질관리시스템

각종 품질검사
부적합관리-품질뱅크
계측기 검교정
문서관리
견적 및 개발품 관리



TPS
설비관리시스템

설비관리
금형관리
비가동관리



Barcode
바코드모드

바코드화
현장점검·검사
작업등록



Our Differentiation Strategies

현재에 안주하지 않고
더 나은 제품과 서비스 제공을 위한 노력을 멈추지 않습니다.



Process Flow

각 공정 간 기본과 원칙을 준수하며 불량공정률 0%를 향해 최선을 다합니다.



PRODUCTS &
EQUIPMENT



완제품 (자동차)

O/S CLIP



I/S SUPPORT



O/S CLAMP



SUPPORT PLATE



SPRING PLATE



O/S BRACKET



DAMPER



PRODUCTS &
EQUIPMENT



완제품 (군수)

O/S BRACKET

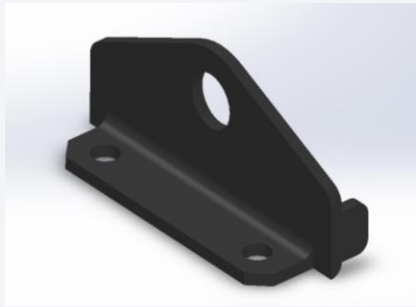

O/S BRACKET L

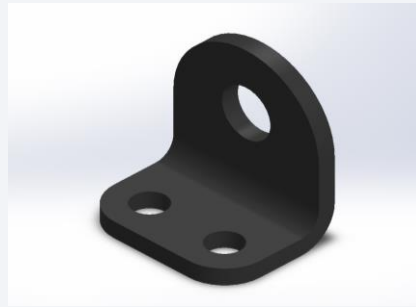

UNDER BODY

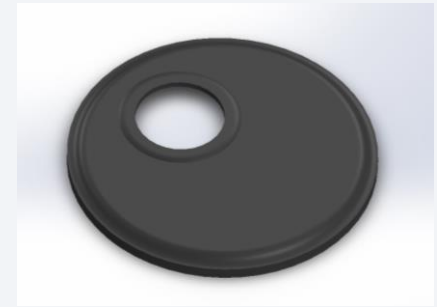

O/S BRACKET

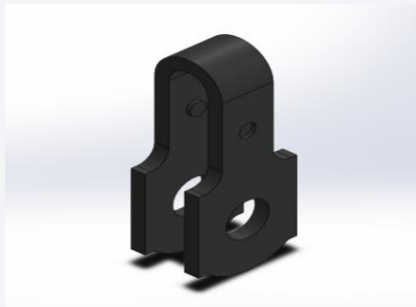

UN BODY INNER

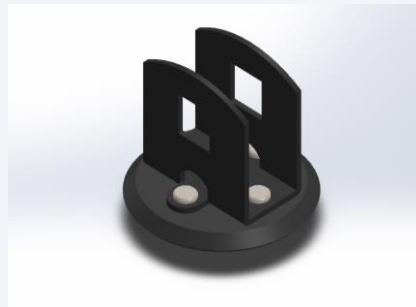

BODY BRACKET

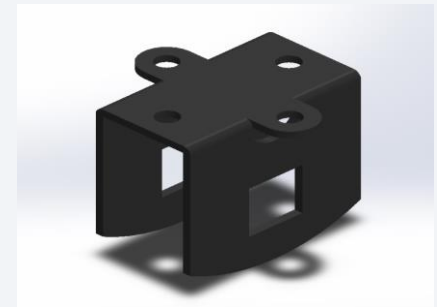

PRODUCTS &
EQUIPMENT



완제품 (기타)

걸름판

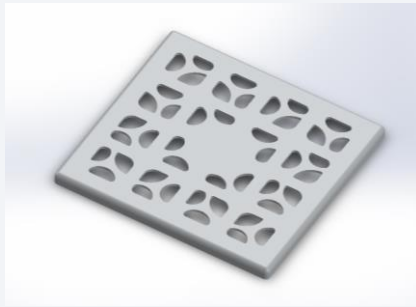

포밍판

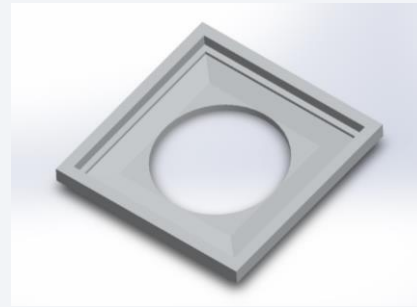

튜브 누름판

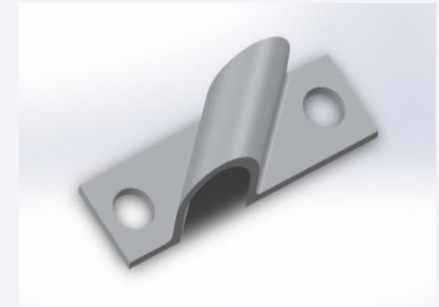

CLIP

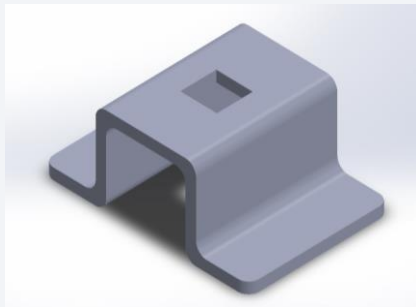

CLIP



CLIP



PRODUCTS &
EQUIPMENT



설비

생산설비 for manufacturing



설비명	규격	보유대수
CS PRESS	200 ton	1
CS PRESS	150 ton	2
CS PRESS	80 ton	1
CS PRESS	75 ton	2
POWER PRESS	50 ton	1

공정설비 for processing



설비명	규격	보유대수
선반	800*1200	1
레디알	1000	1
콘타	300*450	1
연마기	270*550	1
밀링	1100*280	1
드릴	1000	2
탭핑기	-	4

측정설비 for measurement



설비명	규격	보유대수
비전측정기	300*200	1
도금측정기	0-625 μ m	1
전자저울	25-6000 g	1
	2-1000 g	1
버니어캘리퍼스	0-200 mm	6
마이크로미터	0-25 mm	4

WE ARE CUSTOMER-ORIENTED

우리는 고객중심의 가치를 알고, 이를 업무에 적용해왔습니다.
언제나 변함없는 신뢰를 드리는 동반자가 되겠습니다.



경기도 시흥시 범안로 382

T. 031 404 5256~7 E. shinwontech2016@naver.com H. www.shinwontec.com